

Accurate flow control of hydrocarbon products:

Brodie Model BV Valves

The superior pilot operated piston valves

The Control Valves offered by Brodie International are self contained, balanced piston, spring biased to the closed position, pilot operated valves that can be configured to perform a wide variety of control functions.

Whether your application is loading terminals, aircraft refueling, flow rate control, on-off control, pressure control, pump control or tank safety applications, Brodie has a control valve designed to meet your particular needs.

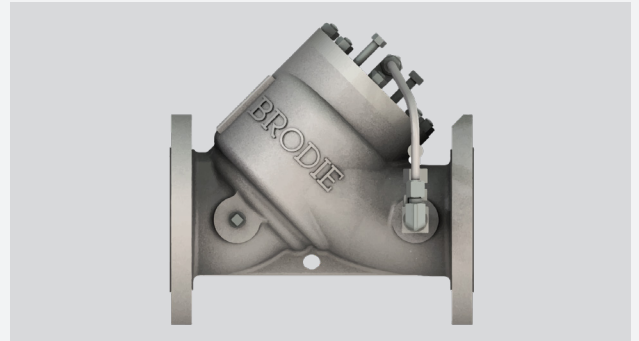

Every drop counts.

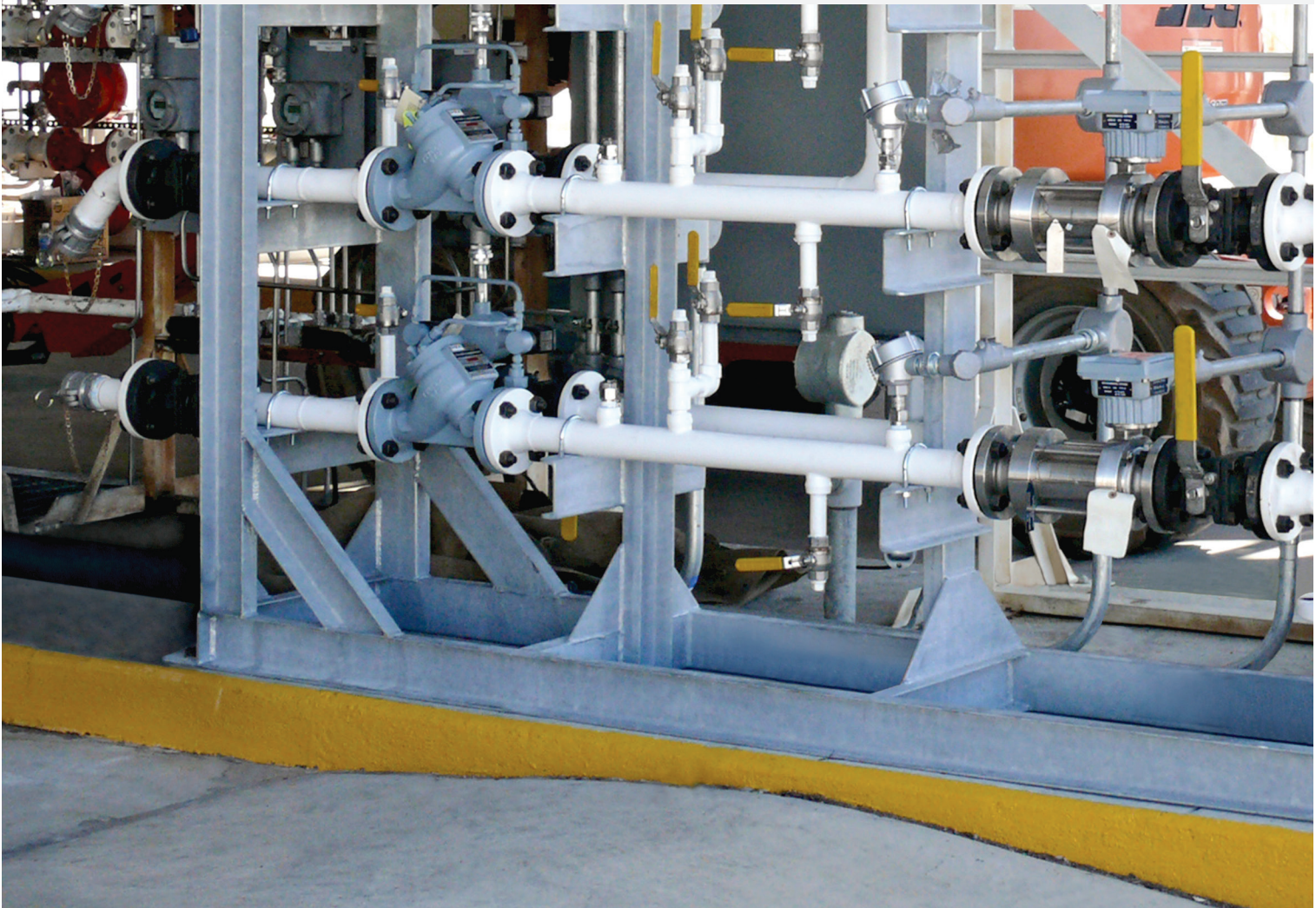

Total Control at all times

Designed to meet the challenges for today's petroleum and environmental needs, Brodie's positive sealing and linear action control valves provide uniform speed of response and leak-proof performance.

Reduced Cost of Ownership

- Long service life, only one moving part
- Complete internals including cylinder, piston and seat ring can be removed without removing body from the line
- Complete internal cylinder assemblies available as replacement kits

Security & Control

- Automatic shutoff for emergency protection
- Pressure monitoring at all times

Uniform Speed of Response

- Flow modulation avoids delayed response and damaging surge pressures

Features

- Pilot operated
- Positive sealing / ANSI CL. VI shut off
- Modular construction / Easy inline service
- Adjustable opening and closing speeds prevent damaging shock pressure
- Linear action control for uniform speed of response
- Simple design without diaphragms
- Common valve body and internal mechanism simplifies spare parts inventory
- Multiple control functions can be performed with one valve

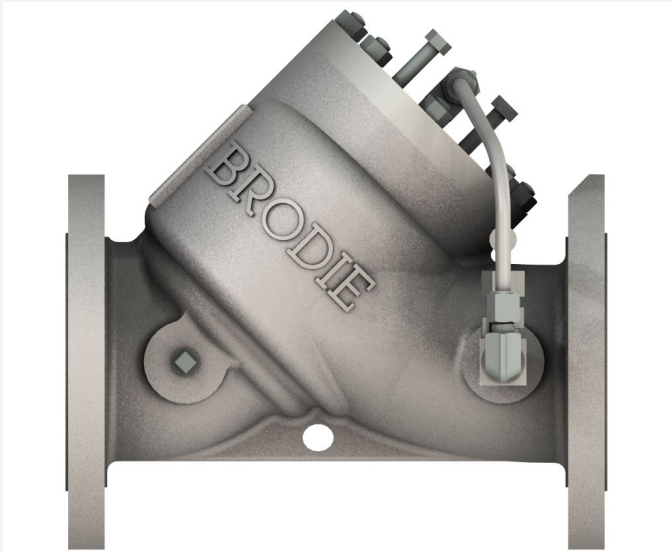

Design Features

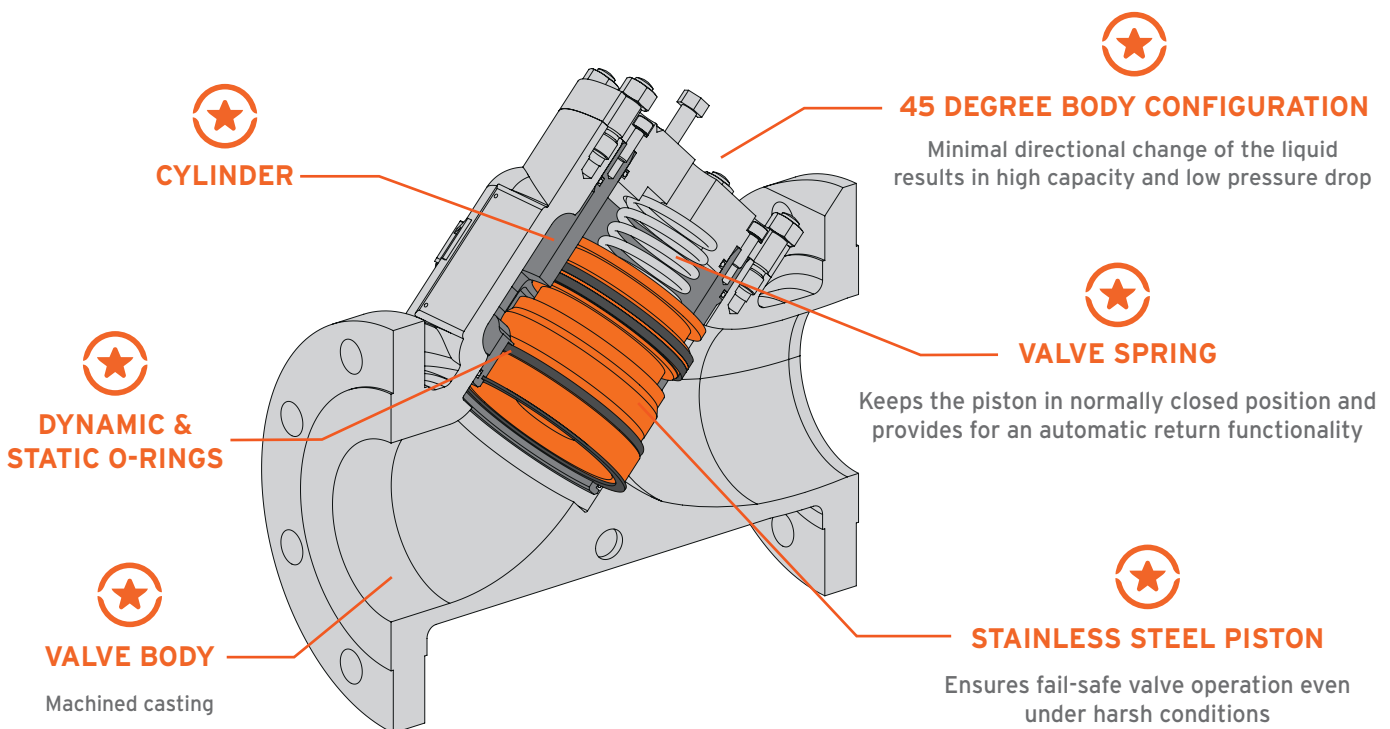

Piston-Operated Valves vs. Diaphragm Valves

There are many advantages in using piston-operated control valves as opposed to diaphragm-operated valves, including:

- Higher flow capacity - lower pressure drop
- Linear control provides more precise pressure/flow control
- Optimum control at low flow gives better batching control
- Simple O-ring sealing - no special diaphragms
- Alternative O-rings easily obtainable if product specifications change at a later date

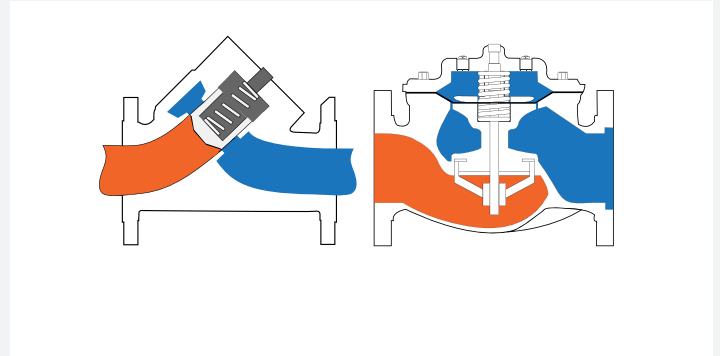

Linear Operating Performance

With a piston valve, there is a linear relationship between percentage open and flow rate, giving much better control. Linear control also minimizes water hammer and surge pressures, especially in an emergency shutdown. The characterized cylinder ports provide exceptional control, preventing instability, especially at low flow rates.

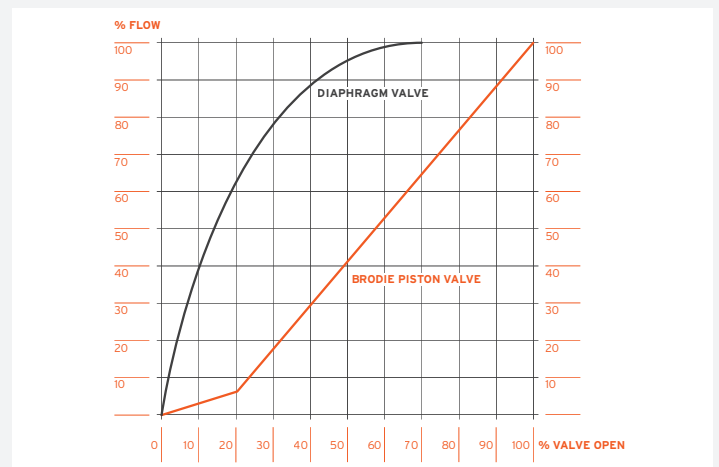

Balanced Piston Design

The main valve piston, spring biased to the closed position, is hydraulically balanced as it has equal front and rear surface areas.

This means the spring is the only closing force and, along with the rectangular port openings located 360 degrees around the cylinder, characterized with a low flow opening at the bottom of the ports, result in excellent control over a wide range of flows.

As an option, all Brodie pilot operated valves can be ordered and configured as non-return check valves, eliminating the need for additional valves in the system.

How do pilot operated valves work?

Pilots are devices added to the basic valve which are used to position the valve piston open or closed as required by the application. There are two basic pilot types:

On/Off pilot

These are electrically switched pilots which position the valve- open or closed.

UL, CSA, ATEX, IECEX, NEPSI [China] etc. certification available.

Pressure regulating pilot

These pilots allow the valve to be throttled to any degree necessary to provide various pressure control schemes.

On/Off pilot

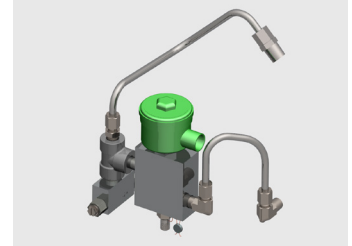

Pressure regulating pilot



Self Regulation

Valves which utilize only pressure regulating pilots are completely self regulating, requiring no external actuation or other energy source.

Once the pilots are set, the valves will continue to function automatically until such times as settings are changed.

There is no need for any external pressure measurement or regulation. Just "set and forget".

Valve fitted with pressure regulating pilot

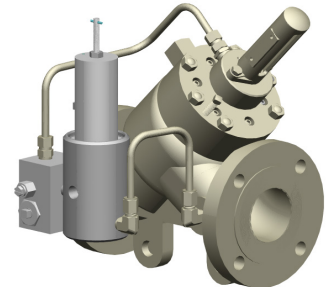

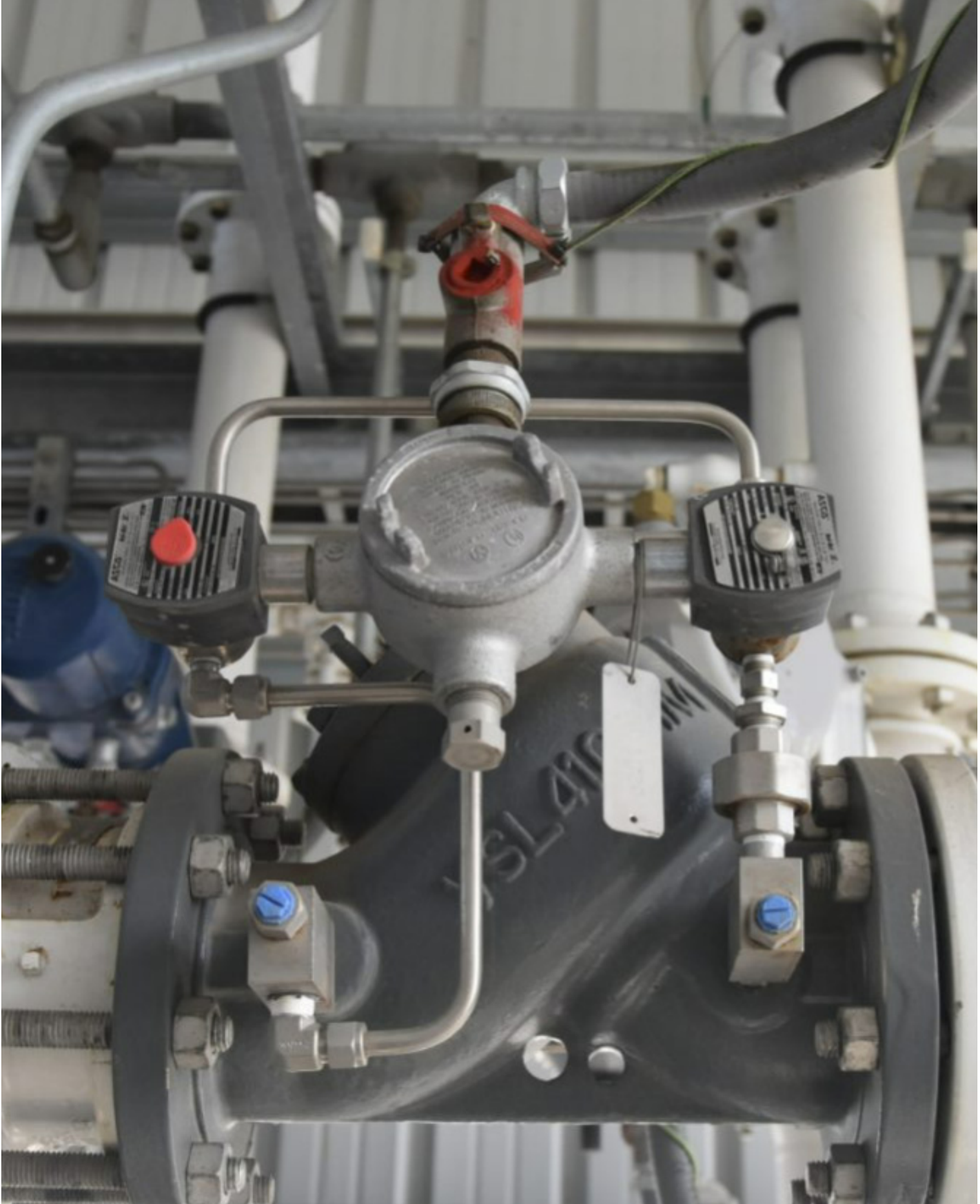

Highly versatile: the different types of BV Valves

The Brodie Control Valve is the most versatile in the market. A single valve can incorporate one or multiple control functions to meet the exact requirements for on/off and modulating control of liquid products.

Control combinations are virtually unlimited. The different functions are provided in a single standard body with different pilots.

Brodie valves are pressure balanced, single seated and pilot operated. The valves are hydraulically operated and use the flowing fluid stream as the power medium. They are equipped with a needle valve in the pilot supply line for adjusting the closing rate and for sensitivity control. A strainer is incorporated in the pilot flow line upstream of the needle valve.

Brodie valves are designed to offer economic solutions while meeting the most stringent demands of aggressive product applications such as product blending using MTBE, TAME, Methyl alcohols, reformulated fuels, solvents etc.

By utilizing a combination of fluid product elastomers, Brodie has developed this highly versatile control valve option.



BV 02 and BV 03: Check Valve, Basic Function Model

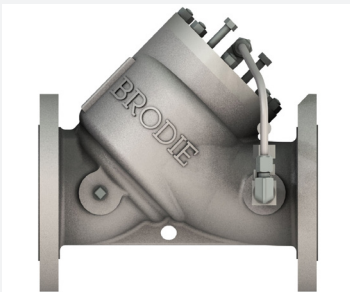

BV02 [with manual valve]

The Brodie BV02 Check Valve is designed to provide smooth, shock-free opening and closure to prevent reverse flow.

Non-Surge Check

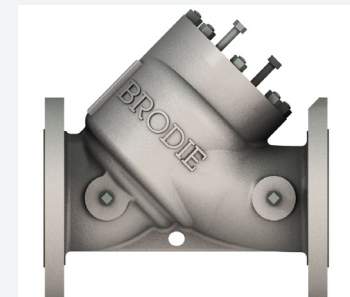
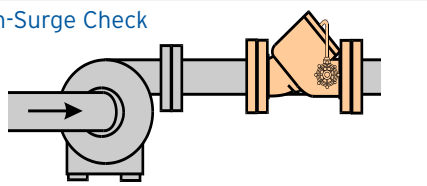

BV03 [without manual valve]

The Brodie BV03 is supplied as a basic valve with no controls. It is utilized as replacement or original equipment in applications where custom control is desired by the end user. As with all Brodie BV Control Valves, it may be adapted for hydraulic, pneumatic or solenoid pilot control.

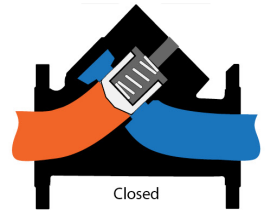

Closed

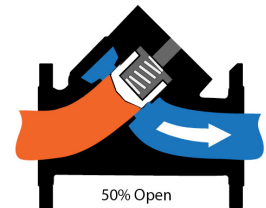

50% Open

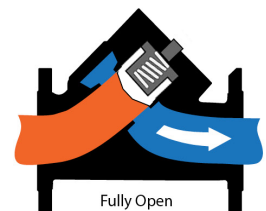

Fully Open

BV 10 and BV 11: On/Off Control Valve



The BV 10 is the normally closed and the BV 11 is the normally open version of this solenoid operated valve designed for remote On/Off control applications. Select either NO or NC for required fail-safe strategy.

The pilot valve is a fully balanced, two-way valve with integral manual override features. The external piping is fitted with a strainer [pilot control line] and a needle valve for controlling the speed of closure and for sensitivity control.

Typical applications include timing or cycling processes, batch control, deadman, high level tank control or emergency shut-down.

Remote or local On-Off

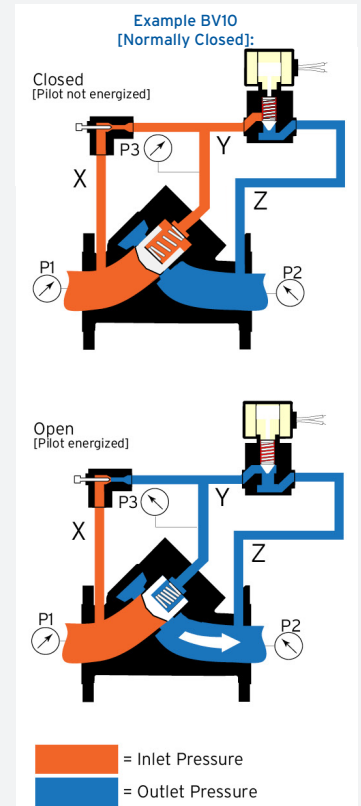
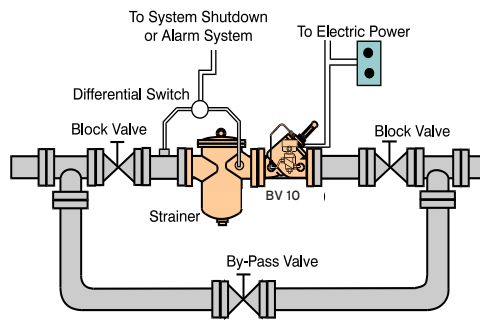

BV 28: Power Cylinder operated Digital Control Valve

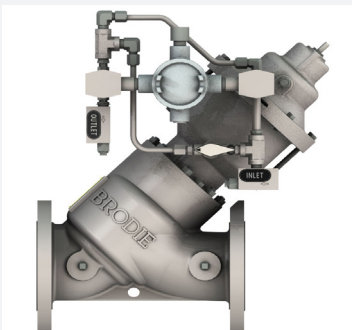

- Pneumatic or hydraulic operation
- Minimum Pressure Drop
- Fail-safe/bubble tight shut-off
- Available for on/off two stage or digital control pneumatic and hydraulic positioning
- Ideal for use in tank safety, remote on/off control or by-pass control on distribution systems, automatic drainage from storage and emergency shut-off on loading and unloading lines

BV 50: Pressure Reducing Valve

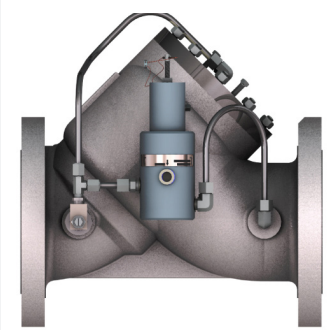

The Model BV50 Pressure Reducing Valve is designed for close regulation of downstream pressure. Typical applications include petroleum distribution systems, make-up control and over pressure of meters and pipelines.

Constant downstream pressure is maintained within ± 2 psi [13.8 kPa] or better, regardless of variation in flowrate or upstream pressure.

- Close regulation for downstream pressure
- Over-pressure protection
- Uniform response speed
- Positive shut-off

Pressure Regulation

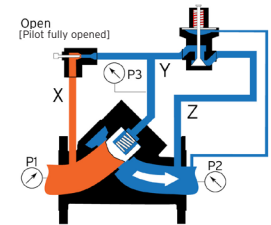
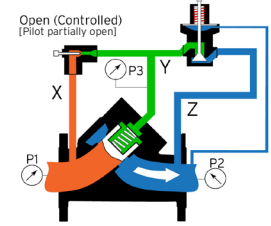
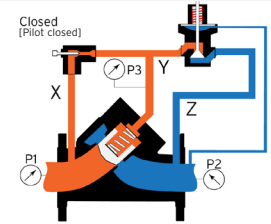
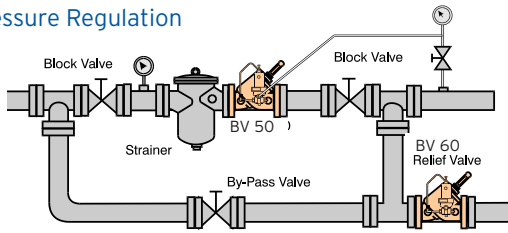

BV 54: Flow Limiting Valve

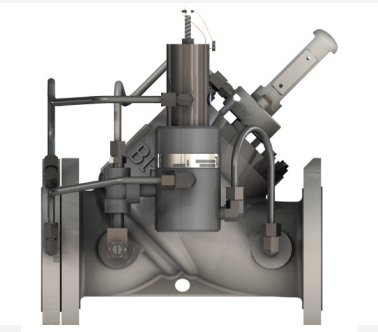

The Brodie BV54 Flow Limiting Valve controls maximum rate of flow to $\pm 2\%$ regardless of variations in the upstream or downstream pressure.

Although normally used to control the flow rate through a meter, the BV54 can be used for any application requiring accurate, dependable flow control.

- Accurate, dependable flow rate control
- Uniform response speed

Rate of Flow Control

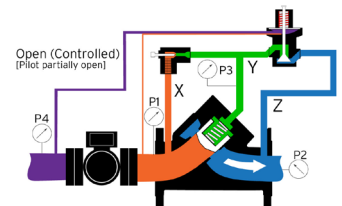
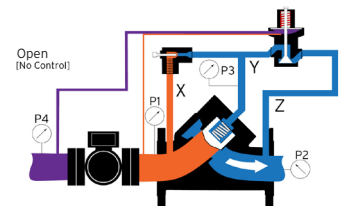
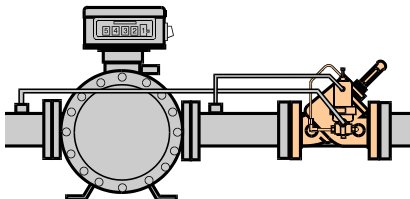



BV 60: Back Pressure Control/Pressure Relief Valve

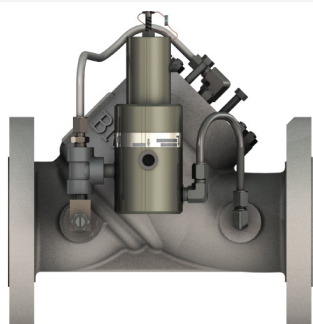

The Brodie BV60 Back Pressure Control/Pressure Relief Valve is designed for close regulation of back pressure, pressure relief and surge control.

In applications for metering systems or pipelines, the BV60 is used to hold a minimum back pressure on the outlet of a meter for more consistent operating conditions. In applications of pump relief or bypass, the valve is used to relieve excess pressure.

A constant back pressure is maintained within +/- 2 psi [13.8 kPa] of set point, regardless of variations in flow rate or upstream pressure.

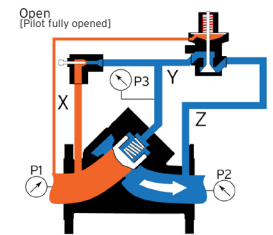
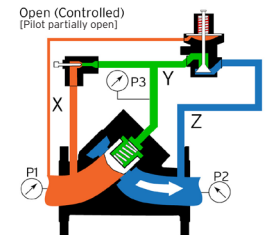
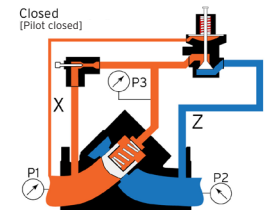

Orange = Inlet Pressure
Blue = Outlet Pressure
Green = Control Pressure

Pressure Control

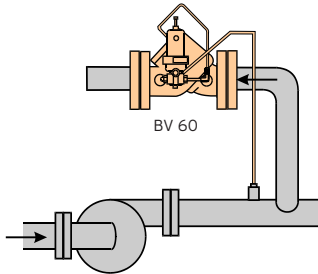

Pressure Relief

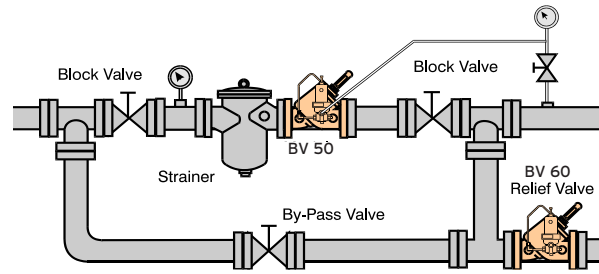

BV 70: Differential Control Valve

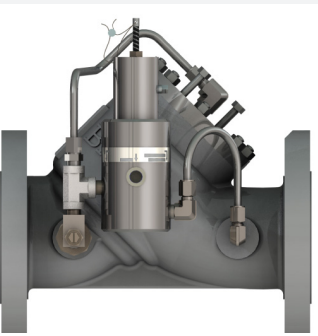

The Brodie BV70 Differential Control Valve is a normally closed, regulating or positioning type valve designed for applications requiring valve closure on decreasing pressure differential such as pump differential pressure control and vapor pressure control for products with high flash points.

It does not require an outside power source to operate. A controlled pressure differential is maintained within +/- 2% regardless of variations in upstream or downstream pressure.

The pilots are balanced, single seated valves with large ports and will operate on a differential as low as 5 psi [34.5 kPa].

- Completely self contained
- Maintains controlled pressure differential
- Uniform response speed

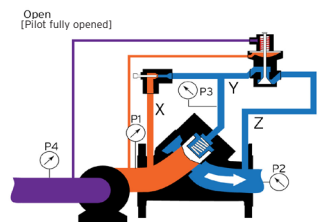
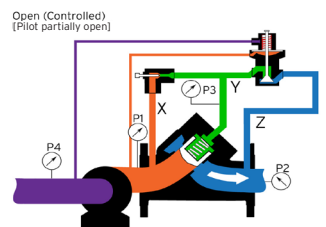
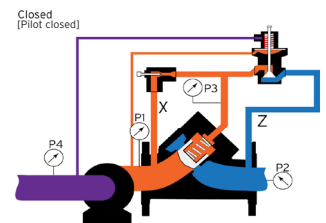

Orange = Inlet Pressure
Blue = Outlet Pressure
Green = Control Pressure

Differential Pressure Control

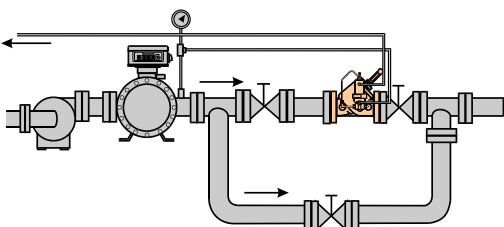

BV 88: Digital Control Valve

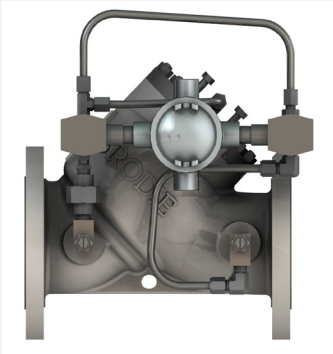

- Precision Flow Rate and Batch Control
- Fail safe, closes on power failure
- Compatible with electronic presets
- Controlled by electronic device for low-flow start-up, high flow control, low flow shut-down and final shut-off
- Linear control characteristics result in a constant flow rate - even in varying line pressure conditions without water hammer
- Allows optimum meter performance and avoids overflow due to fast response
- Features an external pilot control loop that consists of a normally open solenoid pilot, a normally closed solenoid pilot, a strainer and opening/closing speed controls

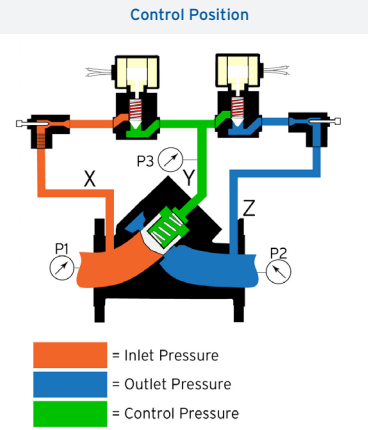

BV 89: Two-stage Control Valve

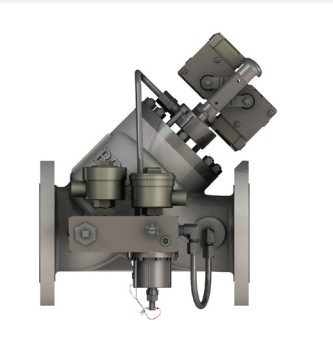

The BV89 Control Valve is a normally closed, two-stage electrical valve designed for precise, accurate shut-off of petroleum products. In applications such as petroleum loading racks, where product delivery is predetermined and metered, the valve reduces flowrate before final shut-off to minimize pressure surge and line shock. Two-stage opening is also available.

The pilots are balanced, single seated valves with large ports and will operate on a differential as low as 5 psi [34.5 kPa].

- Accurate two-stage shut off
- Minimizes surge pressure and line shocks
- Provides maximum flow rate control
- Uniform response speed

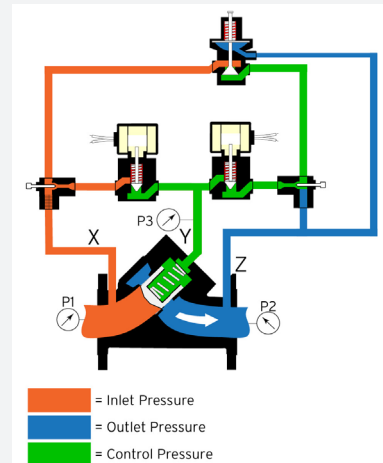

BV 86: Two Stage Mechanical Control Valve

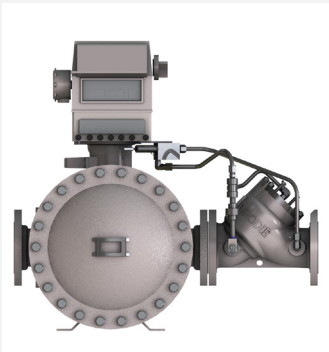

This valve is normally used with a PD meter or Mechanical Batch Preset Unit, to give close tolerance batch control and shock free closure.

No external power is needed - the valve is operated hydraulically by the flowing liquid being metered.

Typical applications include ship refuelling from bunkering barges where no power supply is available.

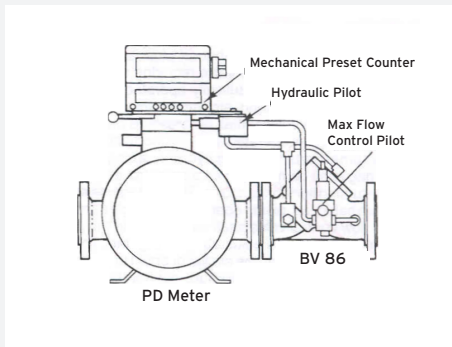

Multiple piloted valves

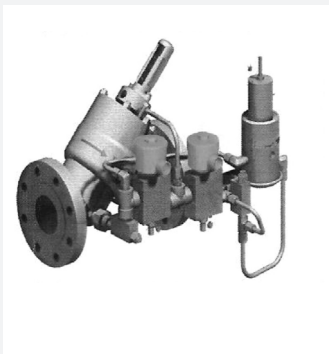

Multiple pilots can be employed in a series or parallel with a pilot panel mounted to the main valve. During operation, the specific function required is in control. Only one pilot operates the main valve at a time.

Panels are furnished with block valves, strainer and sensitivity response needle valves. These valves can furnish many different functions in a single valve body.

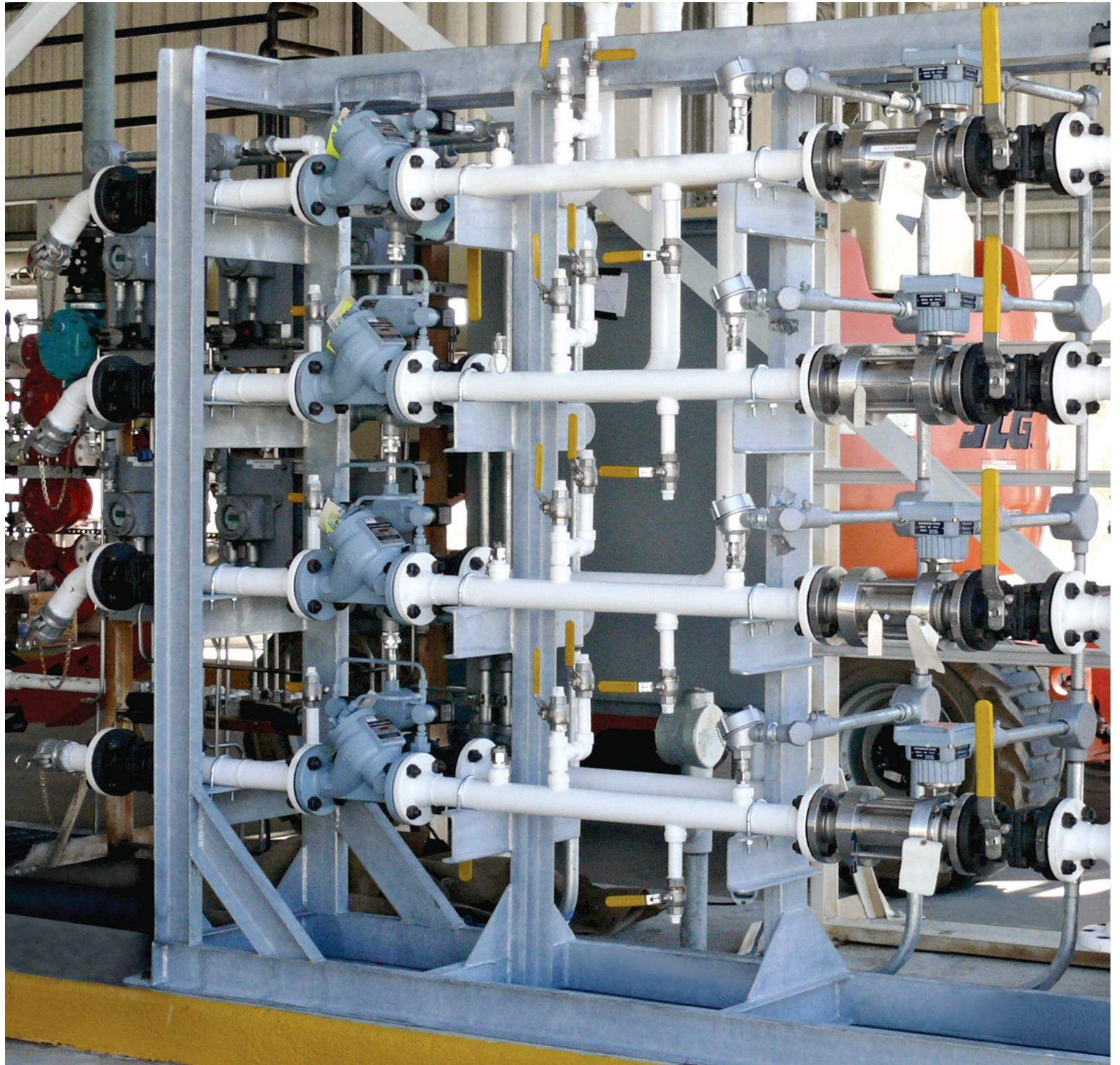

BRODIE
INTERNATIONAL

Brodie International

P.O. Box 450 (30459-0450)
19267 Highway 301 North
Statesboro, GA 30461,
USA

Email: sales@brodieintl.com
Phone: +1 (912)489-0200
Fax: +1 (912) 489-0294